

# **Instrument Messages and Functional Tests**

## **Agilent Technologies E4406A VSA Series Transmitter Tester**



**Manufacturing Part Number: E4406-90184**

**Printed in USA**

**August 2001**

© Copyright 2001 Agilent Technologies

The information contained in this document is subject to change without notice.

Agilent Technologies makes no warranty of any kind with regard to this material, including but not limited to, the implied warranties of merchantability and fitness for a particular purpose. Agilent Technologies shall not be liable for errors contained herein or for incidental or consequential damages in connection with the furnishing, performance, or use of this material.

---

## **Where to Find the Latest Information**

Documentation is updated periodically. For the latest information about Agilent VSA transmitter testers, including firmware upgrades and application information, see: <http://www.agilent.com/find/vsa>.

## 1. Instrument Messages

Status Annunciators (Front Panel) .....	6
Informational Messages, Not Numbered .....	7
Negative Error Message Numbers:	
General Usage Error Messages .....	9
–499 to –400: Query Errors .....	9
–399 to –300: Device-Specific Errors .....	10
–299 to –200: Execution Errors .....	12
–199 to –100: Command Errors .....	18
Positive Error Message Numbers:	
Instrument-Specific Error Messages .....	23
1 to 99: Core Error Messages .....	23
100 to 199: GSM Error Messages .....	27
200 to 299: cdmaOne Error Messages .....	29
300 to 399: NADC Error Messages .....	30
400 to 499: PDC Error Messages .....	31
500 to 599: W-CDMA Error Messages .....	31
600 to 699: cdma2000 Error Messages .....	32
Error Message Queues .....	33
Clearing the Error Queue .....	33
No Errors Over the Remote Interface .....	33
Error Message Format .....	33
Error Queue (Front Panel) .....	35
Error Queue (Programming Interface) .....	36
Remote Error Queue .....	36
Querying the Error Queue .....	36

## 2. Functional Testing

Getting Started .....	40
Before You Start .....	40
Test Equipment .....	40
Equipment Connections .....	40
Required Test Equipment .....	41
Functional Tests .....	42
Frequency Response (Flatness) .....	43
Test Limits .....	43
Test Description .....	43
Required Equipment .....	43
Procedure .....	44
Amplitude Accuracy at 50 MHz .....	48
Test Limits .....	48
Test Description .....	48

---

## Contents

Required Equipment .....	48
Procedure .....	49
Input Attenuator Accuracy at 50 MHz .....	53
Test Limits .....	53
Test Description .....	53
Required Equipment .....	53
Procedure .....	53
Displayed Average Noise Level (DANL) .....	56
Test Limits .....	56
Test Description .....	56
Required Equipment .....	56
Procedure .....	57
Phase Noise .....	59
Test Limits .....	59
Test Description .....	59
Required Equipment .....	60
Procedure .....	60
Residual Responses .....	65
Test Limits .....	65
Test Description .....	65
Required Equipment .....	65
Procedure .....	65
<b>Index. ....</b>	<b>69</b>

- [“Status Annunciators \(Front Panel\)” on page 6.](#)

These messages indicate conditions that can cause the display of incorrect data.

- [“Informational Messages, Not Numbered” on page 7.](#)

These messages simply provide information. You are not required to do anything when they are displayed.

- [“Negative Error Message Numbers: General Usage Error Messages” on page 9.](#)

These messages appear at the bottom of the screen and normally indicate that you are using the instrument incorrectly, either from the front-panel or remotely.

- [“Positive Error Message Numbers: Instrument-Specific Error Messages” on page 23.](#)

These messages appear at the bottom of the screen and indicate that the instrument has detected an error: within the GPIB system, within the instrument firmware, within instrument hardware, during the transfer of block data, or during calibration.

- [“100 to 199: GSM Error Messages” on page 27.](#)
- [“200 to 299: cdmaOne Error Messages” on page 29.](#)
- [“300 to 399: NADC Error Messages” on page 30.](#)
- [“400 to 499: PDC Error Messages” on page 31.](#)
- [“500 to 599: W-CDMA Error Messages” on page 31.](#)
- [“600 to 699: cdma2000 Error Messages” on page 32.](#)

- [“Error Message Queues” on page 33.](#)
- [“Error Queue \(Front Panel\)” on page 35.](#)
- [“Error Queue \(Programming Interface\)” on page 36.](#)

## Status Annunciators (Front Panel)

The display annunciators show the status of some of the transmitter tester functions and indicate error conditions of the instrument. Error annunciators are shown in red text on the instrument display. Where applicable, some states will appear in green, indicating that the feature is active and performing correctly. The state will change to red if the feature fails. The following annunciators are available:

**Unlock** - This annunciator indicates that one or more of the internal phase-locked loops are unable to maintain a phase-locked state.

**Corr Off (corrections off)** - This annunciator appears when the **Corrections** softkey is set to off.

**Err (error)** - This annunciator appears when an error message is placed in the history error queue. It will persist until you use the **Clear Error Queue(s)** key to clear the history error queue.

**Ext Ref (external reference)** - The green **Ext Ref** annunciator indicates that the external reference has been selected and the instrument is locked to it. The red **Ext Ref** annunciator indicates that the external reference has been selected, but the instrument is not locked to that reference. Note that the external reference on this instrument can be set at any frequency between 1 and 30 MHz; if the entered value does not correspond to the external reference that is in use, a red **Ext Ref** annunciator will appear. Also, be aware that the value entered for the external reference frequency will persist, even after the instrument has been powered off. The user must manually enter a new value for the external reference if a different value is required, even if it corresponds with the default value. An **Ext Ref** annunciator will appear only if the external reference has been activated by the user.

**ESec (even second clock)** - The green **ESec** annunciator indicates that the external even second clock has been selected as the sync type and a sync signal is present at the even second input (rear panel **Trigger In**), and the measurement is using it as the demodulation sync type. The red **ESec** annunciator indicates that an external even second clock has been selected as the sync type but a sync signal is not present at the even second input (rear panel **Trigger In**). In this case, the error message **Even Second Clock Missing** will appear in the **Status/Info** bar at the bottom of the display. The even second clock detection is updated every 2 seconds.

## Informational Messages, Not Numbered

Unnumbered messages are for operator information only. They do not appear in any error queue and do not require any action.

### Description

Acquiring Data...

A warning used when the data acquisition time is long enough to be noticeable.

AFUN not implemented

Awaiting Trigger, no AUTO Trig

Auto Trig is off and a trigger has not been detected for more than 4 seconds.

Break freq > FFT filter edge - clipping to %f kHz

Correction off

Data Acquisition FIFO\_OVERFLOW, use AUTO  
DataPacking..."

Data acquisition malfunction; need to use auto data packing to resolve.

GSM Hopping enabled, waiting for valid burst

When GSM hopping is enabled, this indicates that a valid GSM burst has not yet been found.

IF synthesizer unlocked

LAN external loopback test failed

This message will appear during boot-up if the instrument is not connected to a LAN cable. You can ignore the message if you are not using the LAN.

Please wait - Printing

Waiting for the print job to complete.

Instrument Messages  
**Informational Messages, Not Numbered**

Settling Hardware...

**A warning used when the hardware settling time is long enough to be noticeable.**

Sync is RF ampl (not Training Seq). Bits not accurate.



## Negative Error Message Numbers: General Usage Error Messages

“Generic” SCPI error numbers report common usage errors. Many of these errors are triggered in response to problems controlling the instrument programmatically. They are not sent when the instrument is controlled from the front panel.

### –499 to –400: Query Errors

An error number in the range [–499 to –400] indicates the instrument has found a problem when trying to respond to a SCPI query. The occurrence of any error in this class will cause the error query bit (bit 2) to be set in the event status register. If a query error occurs one of the following is true:

- An attempt is being made to read data from the output queue when no output is either present or pending.
- Data in the output queue has been lost.

### Query Error Message Descriptions

(Number)	Description
(–440)	Query UNTERMINATED after indefinite response  Indicates that a query was received in the same program message after a query requesting an indefinite response was executed (see IEEE 488.2, 6.3.7.5).
(–430)	Query DEADLOCKED  Indicates that a condition causing a DEADLOCKED query error occurred (see IEEE 488.2, 6.3.1.7) (for example, both the input buffer and the output buffer are full and the device cannot continue).
(–420)	Query UNTERMINATED  Indicates that a condition causing an UNTERMINATED query error occurred (see IEEE 488.2, 6.3.2.2) (for example, the device was addressed to talk and an incomplete program message was received).
(–410)	Query INTERRUPTED  Indicates that a condition causing an INTERRUPTED query error occurred (see IEEE 488.2, 6.3.2.7) (for example, a query was followed by DAB or GET before a response was completely sent).

(-400) Query Error

This is a generic query error for devices that cannot detect more specific errors. The code indicates only that a query error as defined in IEEE 488.2, 11.5.1.1.7 and 6.3 has occurred.

### **-399 to -300: Device-Specific Errors**

An error number in the range [-399 to -300] indicates that the instrument has detected an error where some device operations did not properly complete, possibly due to an abnormal hardware or firmware condition. This is not a error in response to a SCPI query or command, or command execution. These errors are also used for self-test response errors. The occurrence of any error in this class will cause the device-specific error bit (bit 3) in the event status register to be set.

#### **Device-Specific Error Message Descriptions**

<b>(Number)</b>	<b>Description</b>
(-362)	Framing error in program message Indicates that a stop bit was not detected when data was received (for example, a baud rate mismatch).
(-361)	Parity error in program message Indicates that the parity bit was not correct when data was received (for example, an incorrect parity bit on a serial port).
(-360)	Communication error This is the generic communication error for devices that cannot detect more specific errors.
(-350)	Queue overflow This is a specific code entered into the queue in lieu of the code that caused the error. This message indicates that there is no more room in the queue and an error occurred but was not recorded.
(-340)	Calibration failed Indicates that the device has detected a failure during its calibration procedure.
(-330)	Self-test failed Indicates that the device has detected a failure during its self-test procedure.

**Negative Error Message Numbers: General Usage Error Messages**

- (-321) Out of memory  
Indicates that an internal operation needed more memory than was available.  
If this occurs during a memory catalog display, it means the system did not have enough free RAM to prepare the catalog.
- (-320) Storage fault  
Indicates that the firmware detected a fault when using data storage. This error is not an indication of physical damage or failure of any mass storage element.
- (-315) Configuration memory lost  
Indicates that non-volatile configuration data saved by the device has been lost. The meaning of this error is device-dependent.
- (-314) Save/recall memory loss  
Indicates that the non-volatile data saved by the \*SAV? command has been lost.
- (-313) Calibration memory lost  
Indicates that non-volatile calibration data has been lost.
- (-312) PUD memory lost  
Indicates that the protected user data saved by the \*PUD command has been lost.
- (-311) Memory error  
Indicates that an error was detected in the device's memory.
- (-310) System error  
Indicates that an error, termed "system error" by the device, has occurred.
- (-300) Device-specific error  
This is a generic device-dependent error for devices that cannot detect more specific errors. The code indicates only that a device-dependent error as defined in IEEE 488.2, 11.5.1.1.6 has occurred.

**–299 to –200: Execution Errors**

An error number in the range [–299 to –200] indicates that an error has been detected during instrument execution. The occurrence of any error in this class will cause the execution error bit (bit 4) in the event status register to be set. If this bit is set, one of the following events has occurred:

- A <program data> element following a header was evaluated by the device as outside of its legal input range or as otherwise inconsistent with the device capabilities.
- A valid program command could not be properly executed due to some device condition.

Execution errors will be reported by the device after rounding and expression evaluation operations have been completed. Rounding a numeric data element, for example, will not be reported as an execution error.

**Execution Error Message Descriptions**

<b>(Number)</b>	<b>Description</b>
(-294)	Incompatible type  Indicates that the type or structure of a memory item is inadequate.
(-293)	Referenced name already exists  A downloaded program attempted to define an element (a variable, constant, filename, etc.) that had already been defined.
(-292)	Referenced name does not exist  A downloaded program attempted to access an undefined element (a variable, constant, filename, etc.).
(-291)	Out of memory  A downloaded program required more memory than was available in the instrument.
(-286)	Program runtime error  Indicates that a runtime error was detected in a downloaded program.
(-285)	Program syntax error  Indicates that a syntax error appears within a downloaded program. The syntax used when parsing a downloaded program is device-specific.

**Negative Error Message Numbers: General Usage Error Messages**

- (-284) Program currently running  
Indicates that certain operation related to programs may be illegal while the program is running (for example, deleting a running program may be illegal).
- (-283) Illegal variable name  
Indicates that an attempt was made to reference a nonexistent variable.
- (-282) Illegal program name  
Indicates that the name used to reference a program was invalid (for example, redefining an existing program, deleting a nonexistent program, or in general, referencing a nonexistent program).
- (-281) Cannot create program  
Indicates that an attempt to create a program was unsuccessful. This may be due to insufficient memory.
- (-280) Program error  
Indicates that a downloaded program-related execution error occurred. This error message is used when the device cannot detect more specific errors. The syntax used in a program and the mechanism for downloading a program is device-specific.
- (-278) Macro header not found  
Indicates that a syntactically legal macro label in the \*GMC? query could not be executed because the header was not previously defined.
- (-277) Macro redefinition not allowed  
Indicates that the macro label defined in the \*DMC command could not be executed because the macro label was already defined (see IEEE 488.2, 10.7.6.4).
- (-276) Macro recursion error  
Indicates that a syntactically legal macro program data sequence could not be executed because the device found it to be recursive (see IEEE 488.2, 10.7.6.4).
- (-275) Macro definition too long  
Indicates that a syntactically legal macro program data sequence could not be executed because the string or block contents were too long for the device to handle (see IEEE 488.2, 10.7.6.1).

- (-274) Macro parameter error
- Indicates that the macro definition improperly used a macro parameter place holder (see IEEE 488.2, 10.7.3).
- (-273) Illegal macro label
- Indicates that the macro label defined in the \*DMC command was a legal string syntax, but could not be accepted by the device (see IEEE 488.2, 10.7.3 and 10.7.6.2) (for example, the label was too long, the same as a common command header, or contained invalid header syntax).
- (-272) Macro execution error
- Indicates that a syntactically legal macro program data sequence could not be executed due to an error within the macro definition (see IEEE 488.2, 10.7.6.3).
- (-261) Math error in expression
- Indicates that a syntactically legal expression program data element could not be executed due to a math error (for example, a divide-by-zero was attempted). The definition of a math error is device-specific.
- (-260) Expression error
- Indicates that an expression data element related error occurred. This error message is used when the device cannot detect more specific errors.
- (-258) Media protected
- Indicates that the device or user has attempted to write to a read-only memory subsystem (msus). The definition of a protected media is device-specific.
- (-257) File name error
- Indicates that a legal program command or query could not be executed because a file name on the device media was in error (for example, an attempt was made to copy to a duplicate filename). The definition of what constitutes a file name error is device-specific.
- (-256) File name not found
- Indicates that a legal program command or query could not be executed because the file name on the device media could not be found (for example, an attempt was made to read or copy a nonexistent file). The definition of what constitutes a file not being found is device-specific.

**Negative Error Message Numbers: General Usage Error Messages**

- (-255) Directory full
- Indicates that a legal program command or query could not be executed because the media directory was full. The definition of what constitutes a full media directory is device-specific.
- (-254) Media full
- Indicates that a legal program command or query could not be executed because the media was full (for example, there was no space left on the disk). The definition of what constitutes full media is device-specific.
- (-253) Corrupt media
- Indicates that a legal program command or query could not be executed because of corrupt media, for instance a bad disk or incorrect disk format. The definition of what constitutes corrupt media is device-specific.
- (-252) Missing media
- Indicates that a legal program command or query could not be executed because of missing media, for instance no disk in the disk drive. The definition of what constitutes missing media is device-specific.
- If this occurs during a memory catalog display, it means the default memory system could not be located. The instrument is likely not functioning properly. Report this error to the nearest Agilent Technologies Sales and Service office. Refer to the Sales and Service Office table in the user's guide for your instrument.
- (-250) Mass storage error
- Indicates that a mass storage error has occurred. This message is used when a device cannot detect more specific errors.
- (-241) Hardware missing
- Indicates that a legal program command or query could not be executed because of missing device hardware (for example, an option was not installed).
- (-240) Hardware error
- Indicates that a legal program command or query could not be executed because of a hardware problem in the device. The definition of what constitutes a hardware problem is completely device-specific. This error is used when the device cannot detect more specific errors.

- (-233) Invalid version
- Indicates that a legal program data element was parsed but could not be executed because the version of the data is incorrect to the device. This particular error is used when file or block data elements are recognized by the instrument, but cannot be executed for reasons of version incompatibility (for example, a non-supported file version or a non-supported instrument version).
- (-232) Invalid format
- Indicates that a legal program data element was parsed but could not be executed because the data format or structure is inappropriate (for example, when loading memory tables or when sending a `SYSTEM:SET` parameter for an unknown instrument).
- (-231) Data questionable
- Indicates that the measurement accuracy is questionable.
- (-230) Data corrupt or stale
- Possibly invalid data. A new reading was started but not completed since last access.
- (-226) Lists not same length
- Attempted to use LIST structure having individual LISTS of unequal length.
- (-225) Out of memory
- The device has insufficient memory to perform the requested operation.
- (-224) Illegal parameter value
- Used where exact value, from a list of possibilities, was expected.
- (-223) Too much data
- Indicates that a legal program data element of block, expression or string type was received that contained more data than the device could handle due to memory or related device-specific requirements.
- (-222) Data out of range
- Indicates that a legal program data element was parsed but could not be executed because the interpreted value was outside the legal range defined by the device (see IEEE 488.2 11.5.1.1.5).



**Negative Error Message Numbers: General Usage Error Messages**

- (-221) Settings conflict
- Indicates that a legal program data element was parsed but could not be executed due to the current device state (see IEEE 488.2 11.5.1.1.5).
- (-220) Parameter error
- Indicates that a program data element related error has occurred. This particular error message is used if the device cannot detect more specific errors.
- (-215) Arm deadlock
- Indicates that the arm source for the initiation of a measurement is set to GET and a subsequent measurement query is received. The measurement cannot begin until a GET is received, but the GET would cause an INTERRUPTED error.
- (-214) Trigger deadlock
- Indicates that a trigger source for the initiation of a measurement is set to GET and a subsequent measurement query is received. The measurement cannot begin until a GET is received, but the GET would cause an INTERRUPTED error.
- (-213) Init ignored
- Indicates that a request for a measurement initiation was ignored as another measurement was already in progress.
- (-212) Arm ignored
- Indicates that an arming signal was received and recognized by the device, but was ignored.
- (-211) Trigger ignored
- Indicates that a GET, \*TRG, or triggering signal was received and recognized by the device, but was ignored because of device timing considerations (for example, the device was not ready to respond).
- (-210) Trigger error
- Indicates that a GET, \*TRG, or a triggering signal could not be executed due to an error.
- (-202) Settings lost due to rtl
- Indicates that a setting associated with a hard local control (see IEEE 488.2, 5.6.15) was lost when the device changed to LOCS from REMS or to LWLS from RWLS.

- (-201) Invalid while in local
- Indicates that a command is not executable while the device is in local mode due to a hard local control (see IEEE 488.2, 5.6.1.5) (for example, a device with a rotary switch receives a message which would change the switch's state, but the device is in local, so the message cannot be executed).
- (-200) Execution Error
- This is a generic syntax error for devices that cannot detect more specific errors. The code indicates only that an execution error as defined in IEEE 488.2, 11.5.1.1.5 has occurred.

### **-199 to -100: Command Errors**

An error number in the range [-199 to -100] indicates that an IEEE 488.2 syntax error has been detected by the instrument's parser. The occurrence of any error in this class will cause the command error bit (bit 5) in the event status register to be set. If this bit is set, one of the following events has occurred:

- An IEEE 488.2 syntax error has been detected by the parser. That is, a control-to-device message was received which is in violation of the IEEE 488.2 standard. Possible violations include a data element which violates device listening formats or whose type is unacceptable to the device.
- An unrecognized header was received. Unrecognized headers include incorrect device-specific headers and incorrect or unimplemented IEEE 488.2 common commands.

### **Command Error Message Descriptions**

<b>(Number)</b>	<b>Description</b>
(-184)	Macro parameter error Indicates that a command inside the macro definition had the wrong number or type of parameters.
(-183)	Invalid inside macro definition Indicates that the program message unit sequence, sent with a *DDT or a *DMC command, is syntactically invalid (see IEEE 488.2, 10.7.6.3).
(-181)	Invalid outside macro definition Indicates that a macro parameter place holder (\$<number>) was encountered outside of a macro definition.

**Negative Error Message Numbers: General Usage Error Messages**

- (-180) Macro error
- This error is generated when using a macro or executing a macro. This error message is used if the device cannot detect a more specific error.
- (-178) Expression data not allowed
- A legal expression data was encountered, but was not allowed by the device at this point in parsing.
- (-171) Invalid expression
- The expression data element was invalid (see IEEE 488.2, 7.7.7.2) (for example, unmatched parentheses or an illegal character).
- This error also occurs if a command is executed that is not valid for the current selected instrument mode. Use INSTRUMENT:SELEct to change the mode.
- (-170) Expression data error
- This error is generated when parsing an expression data element. This particular error message is used if the device cannot detect a more specific error.
- (-168) Block data not allowed
- A legal block data element was encountered, but not allowed by the device at this point in the parsing.
- (-161) Invalid block data
- A block data element was expected, but was invalid (see IEEE 488.2, 7.7.6.2) (for example, an END message was received before the end length was satisfied).
- (-160) Block data error
- This error is generated when parsing a block data element. This particular error message is used if the device cannot detect a more specific error.
- (-158) String data not allowed
- A string data element was encountered, but not allowed by the device at this point in the parsing.
- (-151) Invalid string data
- A string data element was expected, but was invalid (see IEEE 488.2, 7.7.5.2) (for example, an END message was received before the terminal quote character).

- (-150) String data error  
**This error is generated when parsing a string data element. This particular error message is used if the device cannot detect a more specific error.**
- (-148) Character data not allowed  
**A legal character data element was encountered where prohibited by the device.**
- (-144) Character data too long  
**The character data element contains more than twelve characters (see IEEE 488.2, 7.7.1.4).**
- (-141) Invalid character data  
**Either the character data element contains an invalid character or the particular element received is not valid for the header.**
- (-140) Character data error  
**This error is generated when parsing a character data element. This particular error message is used if the device cannot detect a more specific error.**
- (-138) Suffix not allowed  
**A suffix was encountered after a numeric element which does not allow suffixes.**
- (-134) Suffix too long  
**The suffix contained more than twelve characters (see IEEE 488.2, 7.7.3.4).**
- (-131) Invalid suffix  
**The suffix does not follow the syntax described in IEEE 488.2, 7.7.3.2, or the suffix is inappropriate for this device.**
- (-130) Suffix error  
**This error is generated when parsing a suffix. This particular error message is used if the device cannot detect a more specific error.**
- (-128) Numeric data not allowed  
**A legal numeric data element was received, but the device does not accept one in this position for the header.**

## Negative Error Message Numbers: General Usage Error Messages

- (-124) Too many digits  
The mantissa of a decimal-numeric data element contained more than 255 digits excluding leading zeros (see IEEE 488.2, 7.7.2.4.1).
- (-123) Exponent too large  
The magnitude of an exponent was greater than 32000 (see IEEE 488.2, 7.7.2.4.1).
- (-121) Invalid character in number  
An invalid character for the data type being parsed was encountered (for example, an alpha in a decimal numeric or a “9” in octal data).
- (-120) Numeric data error  
This error is generated when parsing a data element which appears to be numeric, including non-decimal numeric types. This particular error message is used if the device cannot detect a more specific error.
- (-114) Header suffix out of range  
The value of a header suffix attached to a program mnemonic makes the header invalid.
- (-113) Undefined header  
The header is syntactically correct, but it is undefined for this specific device (for example, \*XYZ is not defined for any device).  
The command (header) may not be valid for the current instrument mode. Use INST:SElect to change the mode.  
The command may not be valid for the current (specified) measurement. (e.g. CALC:WAV:MARK:MAX is not valid because the waveform measurement does not use the marker maximum command.)
- (-112) Program mnemonic too long  
The header contains more than twelve characters (see IEEE 488.2, 7.6.1.4.1).
- (-111) Header separator error  
A character which is not a legal header separator was encountered while parsing the header.

- (-110) Command header error  
An error was detected in the header. This message is used when the device cannot detect more specific errors.
- (-109) Missing parameter  
Fewer parameters were received than required for the header (for example, the \*ESE common command requires one parameter, so receiving \*ESE is not allowed).
- (-108) Parameter not allowed  
More parameters were received than expected for the header (for example, the \*ESE common command only accepts one parameter, so receiving \*ESE 0,1 is not allowed).
- (-105) GET not allowed  
A Group Execute Trigger was received within a program message (see IEEE 488.2, 7.7). Correct the GPIB controller program so that the GET does not occur within a line of GPIB program code.
- (-104) Data type error  
The parser recognized a data element that is not allowed (for example, numeric or string data was expected, but block data was encountered).
- (-103) Invalid separator  
The parser was expecting a separator and encountered an illegal character (for example, the semicolon was omitted after a program message unit).
- (-102) Syntax error  
An unrecognized command or data type was encountered (for example, a string was received when the device does not accept strings).
- (-101) Invalid character  
A syntactic command contains a character which is invalid for that type (for example, a header containing an ampersand, SETUP&).
- (-100) Command error  
This is a generic syntax error for devices that cannot detect more specific errors. The code indicates only that a command error as defined in IEEE 488.2, 11.5.1.1.4 has occurred.

## Positive Error Message Numbers: Instrument-Specific Error Messages

A positive error number indicates that the instrument has detected an error: within the GPIB system, within the instrument firmware, within instrument hardware, during the transfer of block data, or during calibration.

An error number in the positive range indicates that the instrument has detected an error relating to the core operation [1 to 99], or to a personality loaded into the instrument (e.g. GSM [100 to 199] or CDMA [200 to 299]).

### 1 to 99: Core Error Messages

An error number in the range [1 to 99] indicates the instrument has detected an error relating to the core functionality of the instrument.

#### Core-Specific Error Message Descriptions

(Number)	Description
(1)	Synthesizer unlocked  The A19 synthesizer assembly has lost phase lock. Suspect a problem with the A19 hardware or absence of 10 MHz from the A18 reference assembly.
(2)	Frequency reference unlocked  The 100 MHz VCXO on the A18 reference assembly is no longer phase locked. Possible causes are; a faulty internal OCXO, the external reference bad or missing, or faulty phase lock circuitry on the A18 reference assembly.
(3)	Third LO unlocked  The third LO on the A12 analog IF assembly has lost phase lock. Possible causes are; a faulty A12 analog IF assembly, or a missing 10 MHz from the A18 reference assembly.
(4)	Cal oscillator unlocked  The 42.8 MHz calibrator oscillator on the A12 analog IF assembly is unlocked.

- (5) Analog IF sample rate osc unlocked  
**The 30 MHz sample rate oscillator on the A12 analog IF assembly is unlocked.**
- (6) Even second clock failing  
**The even second clock is unlocked.**
- (7) No application file
- (8) Catalog incomplete
- (9) Application not licensed  
**License key “word” is not entered into instrument memory.**
- (10) Application not installed  
**Measurement application could not be found.**
- (11) Invalid application file  
**Caused by an invalid personality file.**
- (12) Application load failed  
**Measurement application could not load.**
- (13) Invalid trace number  
**Caused by an invalid trace number. Some measurements only have 1 or 2 valid traces, rather than the indicated 4.**
- (14) Trace data not ready  
**This may be caused by sending a command that asks for trace data from a measurement that has not finished calculating, or from a measurement that is not currently active (running).**
- (15) Measurement data not available  
**This may be caused by sending a command that asks for data from a measurement that is not currently active (running).**



**Positive Error Message Numbers: Instrument-Specific Error Messages**

- (16) Input Overload Decrease max total power in input.  
**Excessive input power has been detected which will cause the ADC to clip the signal. Reduce the signal level, change the attenuator/max total power setting (under Input menu), or press Restart if the RF Input Range is Auto.**
- (17) Data Acquisition forcing SHORT packing  
**The data acquisition rate is too high to use longer word packing.**
- (18) Command not implemented  
**The requested command is not implemented.**
- (19) Function not implemented  
**The requested function is not implemented.**
- (20) Signal exceeds maximum allowable power - Reduce input power  
**Excessive input power has been detected which will cause the ADC to clip the signal.**
- (21) Memory Allocation FAILURE
- (22) Memory limit caused Data Acquisition to be truncated  
**Caused by a Memory Allocation failure. The measurement limited the acquisition time in order to complete the measurement.**
- (23) Setup INVALID  
**The parameters chosen create a measurement request that is impossible to complete, often due to memory limitations.**
- (24) External reference missing  
**The external frequency reference signal either is missing, has too low an amplitude, or does not match the frequency value previously entered into the instrument memory by the operator.**
- (25) Even Second Clock missing  
**The even second clock signal supplied from the base station is missing. Check the external trigger input connection where the even second clock signal is fed into the instrument.**

- (26) Oven temp low  
**The oven-controlled crystal oscillator is not at the desired operating temperature.**
- (27) Alignment Needed  
**The Auto Align routine needs to be run. At least 24 hours has passed since the last full alignment, or the temperature has changed 6° C.**
- (28) Printer failure  
**Check for proper printer operation.**
- (29) Printer not available  
**The requested printer is not available. Check for proper printer hookup.**
- (30) Printer out of paper  
**Put paper in the printer.**
- (31) Data Acquisition TIMEOUT, repairs underway..."  
**Hardware malfunction, data acquisition subsystem.**
- (32) ADC Alignment Failure  
**One or more built-in alignment tests have failed.**
- (33) IF Alignment Failure  
**One or more built-in alignment tests have failed.**
- (34) RF Alignment Failure  
**One or more built-in alignment tests have failed.**
- (35) System Alignment Failure  
**One or more built-in alignment tests have failed.**
- (51) Synthesizer cal coefficients missing - using defaults (1)  
**The synthesizer calibration data is missing from flash memory. This could be because new flash memory module was installed without transferring calibration data, or there was an incomplete update of the analyzer firmware. You can restore the calibration data from the Recovery Diskette from doing the firmware upgrade process. Otherwise, you should send the analyzer to a service center for calibration.**

## 100 to 199: GSM Error Messages

An error number in the range [100 to 199] indicates the instrument has detected an error relating to the GSM personality.

### GSM - Specific Error Message Descriptions

(Number)	Description
(100)	Not enough data to fit into GSM mask  An attempt to position a GSM trace into the mask, when not enough data was present. Try using the <b>Restart</b> key to clear the problem. This can be caused by a bad GSM burst, or the RF Sync Delay set too far.
(101)	GSM burst out of limits  The GSM signal did not fit into the mask in the Power vs. Time measurement.
(102)	Insufficient pre-Trig for demod - decrease Trig Delay
(103)	Incorrect RBW for demod - change RBW
(104)	Invalid GSM burst timing  A GSM-like burst was acquired, but it's timing is not valid. Ensure the correct <b>Burst Type</b> has been selected.
(105)	Valid GSM burst not found  In a GSM measurement, data was acquired but a GSM burst was not found, with the timeslot mode disabled.
(106)	Cannot synchronize frame trigger  Cannot synchronize the frame trigger to the even second clock.
(107)	Dynamic range not optimum - set AUTO RF input
(108)	Cannot synchronize to RF amplitude (burst error)
(109)	GSM RF sync delay is out of range  Change RF Sync Delay.

- (110) Sync word not found  
**In a GSM measurement using demodulation, the training sequence code (sync word) could not be found.**
- (111) Signal too noisy  
**In a GSM measurement, indicates that a burst could not be found in a signal that appears noisy.**
- (112) Incorrect trigger holdoff - set to 0 sec
- (113) SCPI marker query not available in GSM Rise&Fall
- (114) GSM Pwr Meas requires trig delay < -50us Delay set to -50us
- (115) Carrier frequency outside device's transmit band  
**The entered channel/carrier frequency is not within the range of your current mode setup selection of standard and device.**
- (116) ADC overload -- Carrier not at expected frequency  
**The carrier frequency of the signal may not match the instruments channel frequency setting.**
- (117) Requested timeslot number not present  
**The selected timeslot is not on. (Timeslot is referenced to the trigger point.)**
- (118) Tx Band Spur measurement not defined for mobiles  
**Only base station testing is available.**
- (119) Carrier power too low for optimum dynamic range  
**For better dynamic range, transmit band spur measurements require >10 dBm signal power at the RF input port.**

**Positive Error Message Numbers: Instrument-Specific Error Messages**

- (120) Unexpected carrier frequency (BMT only)  
The transmit band spur measurement only allows bottom (B), middle (M), and top (T) channel frequencies for each supported frequency band. The carrier frequency must be set to the bottom, middle or top frequency of the current frequency band.
- (121) EVM Measurement only supports EDGE TCH burst type
- (122) Unable to demodulate signal
- (123) Input overload  
Excessive input power has been detected which will cause the ADC to clip the signal. Reduce the signal level, change the attenuator setting (under **Input** menu), or press **Restart** if the **RF Input Range** is **Auto**.
- (124) Tx Band Spur measurement does not support this frequency band  
The transmit band spur measurement does not support all of the commercially available frequency bands. You need to change your selection under **Mode Setup, Radio, Band** to one of the supported bands.
- (1??) Valid GSM burst not found for selected timeslot  
In a GSM measurement, data was acquired but a GSM burst was not found, with the timeslot mode enabled.

**200 to 299: cdmaOne Error Messages**

An error number in the range [200 to 299] indicates the instrument has detected an error relating to the cdmaOne personality.

**cdmaOne - Specific Error Message Descriptions**

<b>(Number)</b>	<b>Description</b>
(200)	Signal near noise floor - Power accuracy degraded
(201)	Signal exceeds maximum allowable power - Reduce input power

**Positive Error Message Numbers: Instrument-Specific Error Messages**

- (202) Input overload  
Excessive input power has been detected which will cause the ADC to clip the signal. Reduce the signal level, change the attenuator/max total power setting (under **Input** menu), or press **Restart** if the **RF Input Range is Auto**.
- (203) Channel center frequency outside device's transmit band
- (205) No power at carrier frequency  
No power was detected as a CW or a modulated signal.
- (206) Cannot correlate to input signal  
A correlation failure with the pilot CDMA channel occurred during synchronous demodulation.

**300 to 399: NADC Error Messages**

An error number in the range [300 to 399] indicates the instrument has detected an error relating to the NADC personality.

**NADC - Specific Error Message Descriptions**

<b>(Number)</b>	<b>Description</b>
(300)	Sync word not found In an EVM measurement, the sync word is not found and the synchronization cannot be established when <b>Sync Word</b> is selected in the <b>Burst Sync</b> menu.
(301)	Valid NADC burst not found A valid NADC burst is not found when the <b>Device</b> is MS.
(302)	Signal too noisy The valid EVM measurement cannot be performed, because the input signal is too noisy.
(303)	Burst Delay exceeds 2 ms limit for EVM In an EVM measurement, the <b>Burst Delay</b> value must be less than 2 ms.

## 400 to 499: PDC Error Messages

An error number in the range [400 to 499] indicates the instrument has detected an error relating to the PDC personality.

### PDC - Specific Error Message Descriptions

(Number)	Description
(400)	Sync word not found  In an EVM measurement, the sync word is not found and the synchronization cannot be established when <b>Sync Word</b> is selected in the <b>Burst Sync</b> menu.
(401)	Valid PDC burst not found  A valid PDC burst is not found when the <b>Device</b> is MS.
(402)	Signal too noisy  The valid EVM measurement cannot be performed, because the input signal is too noisy.
(412)	Burst Delay exceeds 2 ms limit for EVM  In an EVM measurement, the <b>Burst Delay</b> value must be less than 2 ms.

## 500 to 599: W-CDMA Error Messages

An error number in the range [500 to 599] indicates the instrument has detected an error relating to the W-CDMA personality.

### W-CDMA - Specific Error Message Descriptions

(Number)	Description
(501)	Signal too noisy
(502)	Input power too low
(503)	Cannot correlate to input signal  Cannot correlate to the input signal and no active channel is found. (from composite EVM measurement)

## 600 to 699: cdma2000 Error Messages

An error number in the range [600 to 699] indicates the instrument has detected an error relating to the cdma2000 personality.

### cdma2000 - Specific Error Message Descriptions

(Number)	Description
(601)	Signal too noisy
(602)	Input power too low
(603)	Can not get long code phase (RS-232) <b>For MS (mobile station) measurements, the long code phase information could not be obtained from the signal at the RS-232 port.(from code domain power measurement or composite EVM measurement)</b>
(604)	Cannot correlate to input signal <b>Cannot correlate to the input signal and no active channel is found. (from composite EVM measurement)</b>



---

## Error Message Queues

If an error condition occurs in the instrument, it may be reported by:

- front panel display (See “Error Queue (Front Panel)” on page 35.)
- remote programming (See “Remote Error Queue” on page 36.)

These two queues are viewed and managed separately. Some programming errors are not applicable to front panel operation, so they are only reported through the remote interface error queue.

Error messages will appear as they occur in the Status/Info bar that is at the bottom of the display. To view error messages fully use the keys in the **System, Show Errors** menu.

---

### NOTE

If there are any messages in the history error queue, the Err annunciator will be present on the instrument display.

---

## Clearing the Error Queue

The error queue will only be cleared upon:

- power up
- receipt of a \*CLS programming command
- reading the last error from the queue

## No Errors Over the Remote Interface

When all the errors have been read from the queue, further remote error queries will return the zero (0) error message. This indicates that the error queue contains no errors.

(Number)	Description
----------	-------------

(0)	No error
-----	----------

The queue is empty. Every error in the queue has been read or the queue was purposely cleared by power-on or \*CLS.

## Error Message Format

Error messages will appear (in the format described below) in the Status/Info bar that appears at the bottom of the display. Generally the most recent message will appear, however there are occasions when an error message that has a higher priority will appear instead of the most recent one.

Error messages appear in the following format:

`<error number><error message><context-specific information><occurrences>`

`<error number>` - **unique numeric identifier**  
(refer to the Error Message Descriptions section)

`<error message>` - **generic description**

`<context-specific information>` - **(optional) additional information**  
**about this particular occurrence of the error**

`<occurrences>` - **Many repetitive type errors are counted rather than being individually logged. Occurrences (enclosed in parentheses) show the number of times the error has occurred since the queue was last cleared.**

## Error Queue (Front Panel)

This history error queue is designed in a circular (rotating) fashion. It can hold up to 250 error messages. If the queue is full, and additional error messages arrive, the oldest errors are lost. The previously read messages are not cleared from the queue; they remain in the queue until they are overwritten by a new error message.

The history error queue information can be accessed by pressing **System, Show Errors**. From this menu you can choose **Top Page**, **Last Page**, **Next Page**, or **Prev Page**, to switch between pages (if there are more than 17 error messages). To empty the queue, press **Clear Error Queue(s)**.

You can exit the error queue display by pressing either **ESC** or **Return**. Selecting a measurement under the **Measure** key will also exit the error queue display.

## Error Queue (Programming Interface)

### Remote Error Queue

This queue is constructed in a linear first-in/first-out fashion. It can hold up to 30 error messages. As errors and events are detected, they are placed in the queue. Unlike the history error queue, errors in this queue are not overwritten by the latest incoming error messages. If the queue overflows, the last error in the queue is replaced with the error:

```
(-350) Queue overflow
```

When the queue overflows, the early errors remain in the queue, and the most recent error is discarded. Reading an error from the beginning of the queue removes that error from the queue, and opens a position at the end of the queue for a new error, if one is subsequently detected.

The queue overflow message remains in the queue until it is read. If errors continue to occur as the queue is read, the `Queue Overflow` message will be followed by as many of the new messages as will fit in the remaining queue space. If the queue fills again and another error occurs, another `Queue Overflow` message will be placed in the queue.

### Querying the Error Queue

The `SYSTEM:ERROR[:NEXT]?` query is a request for the next entry from the instrument's error queue. The instrument responds to the query with the next error number in the queue and its description in the format:

```
<error number><error message><context-specific information>
```

The `<error number>` is a unique error identifier in the range from `-32768` to `32767`. A negative error value indicates a general SCPI programming error, while a positive error is more instrument specific. An error value of zero indicates that no error or event has occurred. Short descriptions of the standard error numbers are described in this section. The `<context-specific information>` section of the error message may contain information which allows you to determine the exact error and context. For example:

```
Invalid suffix; FREQuency:CENT 2.0E+5 dBmV
```

The maximum string length of the `<error message>` including the `<context-specific information>` is 255 characters. The `<error message>` will be sent exactly as indicated in this document, including case. In this example, the context-specific information was the `FREQ:CENT` command.

If there has been more than one error, the instrument will respond with the first one in the queue. Subsequent responses to `SYSTEM:ERROR?` will return errors until the queue is empty.

Instrument Messages  
**Error Queue (Programming Interface)**

These tests check various instrument parameters to offer a high degree of confidence that the instrument is operating correctly. They are recommended as a check of instrument operation for incoming inspection or after a repair. These tests are designed to quickly test an instrument (operating within the temperature range defined by the instrument specifications) using a minimum set of test equipment

---

**NOTE**

The instrument is checked against limits that are wider than the published specifications. If a functional test does not pass, performance verification tests must be run to confirm that a problem exists. Full instrument calibration can only be done using the performance verification and adjustment software.

Measurement uncertainty analysis is *not* available for functional tests.

---

This chapter includes the following:

- [“Getting Started” on page 40.](#)
- [“Required Equipment” on page 43.](#)
- [“Functional Tests” on page 42:](#)
  - [“Frequency Response \(Flatness\)” on page 43.](#)
  - [“Amplitude Accuracy at 50 MHz” on page 48.](#)
  - [“Input Attenuator Accuracy at 50 MHz” on page 53.](#)
  - [“Displayed Average Noise Level \(DANL\)” on page 56.](#)
  - [“Phase Noise” on page 59.](#)
  - [“Residual Responses” on page 65.](#)

## Getting Started

### Before You Start

You must do the following *before* starting functional tests:

1. Ensure you have the proper test equipment, refer to “[Required Test Equipment](#)” on page 41.
2. Switch on the unit under test (UUT) and let it warm up in accordance with warm-up requirements in the instrument specifications.
3. Ensure that the frequency reference is set to internal. To check this, press **System** and **Reference**. The **Ref Oscillator** softkey should have **Int** underlined. If not, press **Ref Oscillator** until **Int** is underlined.

### Test Equipment

“[Required Test Equipment](#)” on page 41 summarizes the equipment you need to run the Functional tests. Some tests, like Flatness, can use various model numbers of a particular equipment type. The “Recommended HP/Agilent Model” will provide the best results. However, the “Alternative HP/Agilent Model” is an acceptable substitute. If neither the recommended nor the alternative test equipment are available, you may use substitute equipment that meets or exceeds the critical specifications listed in the table.

---

**NOTE**

The validity of functional test measurements depends, in part, on the measurement accuracy of the required test equipment used. Verify the proper calibration of all test equipment before running these tests.

---

### Test Equipment Warm-up

Allow sufficient warm-up time for test equipment. Refer to their individual operating or service manuals for warm-up specifications.

### Equipment Connections

Test setups for each test are included with the test. These are in the section titled “[Functional Tests](#)” on page 42.



## Required Test Equipment

Instrument	Critical Specifications	Recommended HP/Agilent Model Number	Alternative HP/Agilent Model Number
<b>Signal Source</b>			
Synthesized Signal Generator	Frequency: 7 MHz to 2.5 GHz Spectral purity: 5 to 1321 MHz SSB Phase Noise: ≤-110 dBc/Hz at 10 kHz offset and ≤-120 dBc/Hz at 30 kHz offset.	8663A	8662A 8664A 8665A 8643A 8644A w/ Option 002
Synthesized Swept Signal Generator	Frequency: 10 MHz to 4.0 GHz Harmonic level: <-40 dBc Amplitude range: +15 to -20 dBm	83620B	8360 series
<b>Meters</b>			
Power Meter	Must be compatible with the power sensor.	EPM- 441A (E4418A)	EMP-442A (E4419A) 437A 438A
Power Sensor	Frequency Range: 7 MHz to 4 GHz. Power Range: -25 dBm to 10 dBm SWR: ≤1.3 Type N (m)	8482A	8481A E4412A 8482A w/Option H84
<b>Terminations</b>			
Termination 50 Ω	Type N (m) Connector Frequency: 7 MHz to 4 GHz	909A option 012	
<b>Miscellaneous Devices</b>			
Power Splitter	Frequency: 1 MHz to 4.3 GHz	11667A	11667B
<b>Cables</b>			
Type N 2 required	Precision Type N 62 cm (24in) (m)	11500C	8120-4781
<b>Adapters</b>			
Type N (f) to N (f)	50 Ω	1250-1472	1250-0777
3.5 mm (f) to N (f)	50 Ω	1250-1745	

## **Functional Tests**

The tests included in this section are:

“Frequency Response (Flatness)” on page 43.

“Amplitude Accuracy at 50 MHz” on page 48.

“Input Attenuator Accuracy at 50 MHz” on page 53.

“Displayed Average Noise Level (DANL)” on page 56.

“Phase Noise” on page 59.

“Residual Responses” on page 65.

## Frequency Response (Flatness)

### Test Limits

Signal amplitude should remain within  $\pm 2$  dB (4 dB peak-to-peak) from 10 MHz to 4 GHz.

### Test Description

The frequency response test measures amplitude error as a function of the tuned center frequency. Measurements are made at various points from 10 MHz to 4 GHz. The signal source amplitude is measured with a power meter to eliminate errors due to source flatness. The power meter is zeroed and calibrated before starting the measurement.

### Required Equipment

(include cables and connectors)

Instrument	Recommended HP/Agilent Model Number	Alternative HP/Agilent Model Number
Synthesized Swept Signal Generator	83620B	8360 series
Power Meter	EPM- 441A (E4418A)	EMP-442A (E4419A), 437A, or 438A
Power Sensor	8482A	8481A, E4412A, or 8482A w/Option H84
Power Splitter	11667A	11667A
Cable: Type N, (2 required)	11500C	
Adapter: 3.5 mm (f) to N (f)	1250-1745	

**Figure 2-1** Power Meter Zero and Calibration Setup

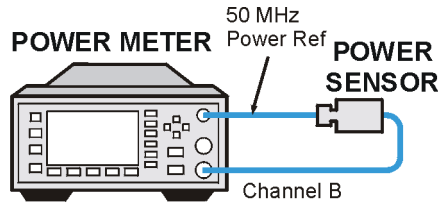

ma86a

**Figure 2-2** Frequency Response Test Setup

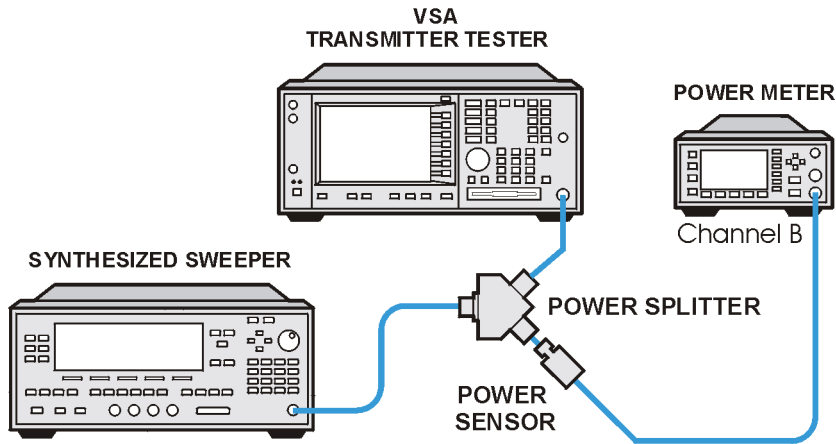

ma810a

## Procedure

1. Configure the power meter and power sensor as shown in [Figure 2-1](#).
2. Zero and calibrate the power meter.
3. Preset the UUT by pressing **Preset**.
4. If the auto alignment for the UUT has not been run within the last hour, run it by pressing **System, Alignment, and Align All Now**
5. Initialize the parameters for the instrument, as listed in [Table 2-1, "UUT Initialization,"](#) by performing the following steps:

- a. Press **MODE, Basic**.
- b. To expand the Spectrum window to full screen, ensure that the Spectrum window is highlighted and press **Zoom**.

If the Spectrum window is not highlighted, press **Next Window** until the Spectrum window is highlighted and then press **Zoom**.

- c. Press **FREQUENCY, Center Freq, 10, and MHz**.

- d. Press **Input**, **Input Atten**, **10**, and **dB**.
- e. Press **Meas Setup**, **Average**, **Avg Number**, **10**, and **Enter**.
- f. Press **View/Trace**, **Trace Display**, and **Average**.
- g. Press **Marker**, **Trace**, and **Spectrum Avg**.

**Table 2-1 UUT Initialization**

Parameter		Setting
Mode		Basic
Measure		Spectrum
Frequency	Center	10 MHz
Input Attenuation		10 dB
Average	On/Off	On
	Mode	Exp
	Type	Log-Pwr Avg
	Number	10
Trace Display		Average
Marker		Spectrum Avg

- 6. Preset the signal source and initialize the test equipment parameters as listed in [Table 2-2, “Signal Source Initialization.”](#)

**Table 2-2 Signal Source Initialization**

Parameter	Setting
Frequency	10 MHz
Amplitude	-4 dBm
RF output	On

- 7. Configure equipment as shown in [Figure 2-2, “Frequency Response Test Setup.”](#)
- 8. Adjust the synthesized sweeper amplitude for a power meter display of -10.00 dBm, ±0.1 dB.

**NOTE** The power level remains unchanged for the duration of the test.

- 9. Press **Search** to position the marker on the peak of the signal.
- 10. Refer to [Table 2-3, “Frequency Responses Report”](#). Enter the amplitude of the signal as displayed on the instrument under the UUT Amplitude Meas<sub>Amp</sub> column of [Table 2-3](#).

11. Enter the power meter reading under the Power Meter Amplitude  $Power_{meter}$  column of [Table 2-3](#).
12. Compute the flatness error using the following equation and record the results under the Flatness Error  $Flat_{error}$  column:

$$Flat_{error} = Meas_{amp} - Power_{meter}$$

13. Perform the following steps for each frequency setting listed in [Table 2-3](#):
  - a. Tune the source to the next frequency listed in the Center Frequency column.
  - b. Set the UUT center frequency by pressing **Frequency, Center, “n”, and MHz**. Where “n” is the next frequency value in the Center Frequency column.
  - c. Press **Search**.
  - d. Enter the power meter reading under the Power Meter Amplitude  $Power_{meter}$  column.
  - e. Enter the instrument reading under the UUT Amplitude  $Meas_{amp}$  column.
  - f. Compute the flatness error using the following equation and record the results under the Flatness Error  $Flat_{error}$  column:

$$Flat_{error} = Meas_{amp} - Power_{meter}$$

The flatness error should be less than  $\pm 2$ dB (4 dB peak-to-peak) from 10 MHz to 4 GHz.

**Table 2-3**      **Frequency Responses Report**

<b>Center Frequency (MHz)</b>	<b>UUT Amplitude Meas<sub>amp</sub> (dBm)</b>	<b>Power Meter Amplitude Power<sub>meter</sub> (dBm)</b>	<b>Flatness Error Flat<sub>error</sub> (dB)</b>	<b>Test Limits (dBm) (dB)</b>
10				±2
400				±2
800				±2
1200				±2
1600				±2
2000				±2
2400				±2
2800				±2
3200				±2
3600				±2
4000				±2

---

## Amplitude Accuracy at 50 MHz

### Test Limits

Amplitude Accuracy should remain within  $\pm 1$ dB of the measured source value across the range of source levels and input attenuator settings.

### Test Description

The amplitude accuracy test measures the absolute amplitude of the instrument at 50 MHz. A synthesized signal generator is used as the signal source for the test. A power meter is used to measure the signal source output-signal amplitude throughout the test. The value measured by the power meter is recorded as  $Input_i$ . The input attenuator of the UUT is set to various values and the source amplitude is varied using the signal generator amplitude control. The signal amplitude is measured by the power meter and the UUT at each setting and the values compared. The difference between each pair of measurements indicates the amplitude accuracy.

### Required Equipment

(include cables and connectors)

<b>Instrument</b>	<b>Recommended HP/Agilent Model Number</b>	<b>Alternative HP/Agilent Model Number</b>
Synthesized Signal Generator	8663A	8662A
Power Meter	EPM- 441A (E4418A)	EMP-442A (E4419A), 437A, or 438A
Power Sensor	8482A	8481A, E4412A, or 8482A w/Option H84
Power Splitter	11667A	11667A
Cable: Type N, (2 required)	11500C	



**Figure 2-3 Amplitude Accuracy Test Setup**

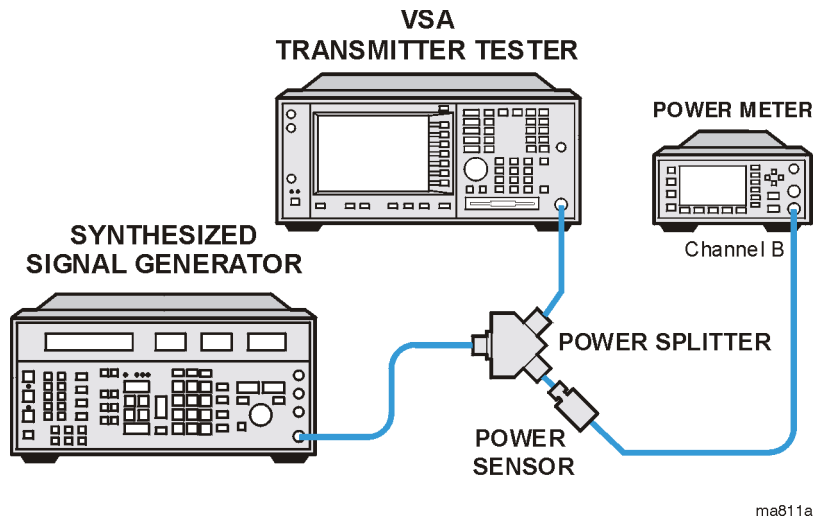

**Procedure**

1. Preset the UUT by pressing **Preset**.
2. If the auto alignment for the UUT has not been run within the last hour, run it by pressing **System, Alignment, and Align All Now**.
3. Initialize the parameters for the instrument, as listed in [Table 2-4, “UUT Initialization,”](#) by performing the following steps:
  - a. Press **MODE, Basic**.
  - b. To expand the Spectrum window to full screen, ensure that the Spectrum window is highlighted and press **Zoom**.  
If the Spectrum window is not highlighted, press **Next Window** until the Spectrum window is highlighted and then press **Zoom**.
  - c. Press **FREQUENCY, Center Freq, 50, and MHz**.
  - d. Press **Meas Setup, Average, Avg Number, 10, and Enter**.
  - e. Press **View/Trace, Trace Display, and Average**.
  - f. Press **Marker, Trace, and Spectrum Avg**.

**Table 2-4**

**UUT Initialization**

Parameter		Setting
Mode		Basic
Measure		Spectrum
Frequency	Center	50 MHz
	Span	1 MHz

**Table 2-4 UUT Initialization (Continued)**

Parameter		Setting
Resolution Bandwidth		20 kHz
Input Attenuation		0 dB
Average	On/Off	On
	Mode	Exp
	Type	Log-Pwr Avg
	Number	10
Trace Display		Average
Marker		Spectrum Avg

4. Preset the signal source and initialize the test equipment parameters as listed in [Table 2-5, “Signal Source Initialization.”](#)

**Table 2-5 Signal Source Initialization**

Parameter	Setting
Frequency	50 MHz
Level	5 dBm

5. Configure the equipment as shown in Figure 2-3, “Amplitude Accuracy Test Setup.”
6. Perform the following steps for each of the nominal measured values listed in [Table 2-6, “Measurement Settings”](#):
  - a. Set the signal source amplitude to the value listed in the Nominal Source Amplitude column in [Table 2-6](#).
  - b. On the UUT, press **Restart** and **Search**.
  - c. Wait for the transmitter tester to finish averaging.
  - d. Adjust the source amplitude, as measured on the UUT, to  $\pm 0.5$  dBm of the value listed in the Nominal Measured Value column in [Table 2-6](#).
  - e. Record the signal amplitude, as measured by the power meter, in the Amplitude Input<sub>i</sub> column of [Table 2-7, “Amplitude Accuracy at 50 MHz Report.”](#)
  - f. Press **Restart**.
  - g. Wait for the transmitter tester to finish averaging, and read the marker value.

- h. Record the signal amplitude, as measured by the UUT, in the Measured Amplitude  $X_i$  column of [Table 2-7](#).

**Table 2-6** Measurement Settings

UUT Nominal Measured Values (dBm)	Nominal Source Amplitude (dBm)	UUT Input Attenuator (dB)
-2	5	0
-12	-5	0
-22	-15	0
2	9	4
-12	-5	4
-22	-15	4
3	10	5
-7	0	5
-17	-10	5
8	15	10
-12	-5	10
-2	5	21

- i. Calculate the amplitude accuracy using the following equation and record in the Error Amp\_Acc<sub>i</sub> column of [Table 2-7](#):

$$\text{Error Amp\_Acc}_i = \text{Input}_i - X_i$$

**Table 2-7 Amplitude Accuracy at 50 MHz Report**

<b>UUT Nominal Measured Values (dBm)</b>	<b>Input Atten (dB)</b>	<b>PowerMeter Amplitude Input<sub>i</sub> (dBm)</b>	<b>UUT Measured Amplitude X<sub>i</sub> (dBm)</b>	<b>Error Amp_Acc<sub>i</sub> (dB)</b>	<b>Test Limits (dB)</b>
-2	0				±1.0
-12	0				±1.0
-22	0				±1.0
2	4				±1.0
-12	4				±1.0
-22	4				±1.0
3	5				±1.0
-7	5				±1.0
-17	5				±1.0
8	10				±1.0
-12	10				±1.0
-2	21				±1.0

---

## Input Attenuator Accuracy at 50 MHz

### Test Limits

The internal input attenuator should reduce the input signal to a value within  $\pm 1.0$  dB of the nominal value at 50 MHz.

### Test Description

The input attenuator accuracy test checks the proper function of the internal attenuator. The attenuation is checked by using the internal 50 MHz calibration signal as a source. The input attenuator of the instrument is set to various values. The internal 50 MHz calibration signal source amplitude is constant. The signal amplitude is measured by the UUT at the 10 dB attenuator setting and recorded as the reference level. Then the signal amplitude is measured by the UUT at additional settings and the measured values compared to the reference level. Because the measured level of the input signal should not vary with changes in input attenuation, the difference between the reference value and the other measured values indicates the attenuator accuracy.

### Required Equipment

None

### Procedure

1. If the auto alignment for the UUT has not been run within the last hour, run it by pressing **System, Alignment, and Align All Now**
2. Preset the UUT by pressing **Preset**.
3. Initialize the parameters for the instrument, as listed in [Table 2-8, "UUT Initialization,"](#) by performing the following steps:
  - a. Press **MODE** and **Basic**.
  - b. To expand the Spectrum window to full screen, ensure that the Spectrum window is highlighted and press **Zoom**.  
  
If the Spectrum window is not highlighted, press **Next Window** until the Spectrum window is highlighted and then press **Zoom**.
  - c. Press **FREQUENCY, Center Freq, 50, and MHz**.
  - d. Press **SPAN, Span, 20, and kHz**.
  - e. Press **Input, Input Atten, 10, and dB**.
  - f. Press **Input, Input Port, and 50 MHz Ref**.

- g. Press **View/Trace**, **Trace Display**, and **Average**.
- h. Press **Amplitude**, **Ref Value**, **-23**, and **dBm**.
- i. Press **Marker**, **Trace**, and **Spectrum Avg**.

**Table 2-8**

**UUT Initialization**

Parameter		Setting
Mode		Basic
Measure		Spectrum
Reference Level		-23 dBm
Frequency	Center	50 MHz
	Span	20 kHz
Resolution Bandwidth		400 Hz
Input Port		50 MHz Ref
Input Attenuation		10 dB
Average	On/Off	On
	Mode	Exp
	Type	Log-Pwr Avg
	Number	25
Trace Display		Average
Marker		Spectrum Avg

- 4. Measure the reference value by performing the following steps:
  - a. Press **Search**.
  - b. Record the marker value as  $X_{ref}$  in the Measured Value  $X_i$  column of [Table 2-9](#), “[Measurement Settings](#).”
- 5. Perform the following steps for each attenuator setting listed in [Table 2-9](#):
  - a. Press **Input**, **Input Atten**, “n”, and **dB**. Where “n” is the attenuation value in the Input Attenuator column of [Table 2-9](#).
  - b. Press **Restart**.
  - c. Press **Search**.
  - d. Read the marker value in dBm.

- e. Record the measured value in the Measured Value  $X_i$  column of [Table 2-9](#).

**Table 2-9 Measurement Settings**

Input Attenuator (dB)	Measured Value $X_i$ (dBm)
0	
1	
2	
4	
5	
10	$X_{ref} =$
20	
40	

6. Calculate attenuator accuracy for each attenuator setting using the following equation:

$$\text{Attenuator\_Error}_i = X_i - X_{ref}$$

7. Record the attenuator error in the Attenuator Error column of [Table 2-10](#), “Attenuator Check at 50 MHz.”

**Table 2-10 Attenuator Check at 50 MHz**

Input Attenuator (dB)	Attenuator Error (dB)	Limit (dB)
0		$\pm 1.0$
1		$\pm 1.0$
2		$\pm 1.0$
5		$\pm 1.0$
10 <sup>a</sup>	0 <sup>a</sup>	$\pm 1.0$
20		$\pm 1.0$
40		$\pm 1.0$

- a. The zero dB setting is the reference level.

## Displayed Average Noise Level (DANL)

### Test Limits

The DANL test results should be within the following limits in the four frequency ranges tested:

**Table 2-11**

Frequency	Limits (dBm)
7 MHz to 20 MHz	$\leq -90$
20 MHz to 2 GHz	$\leq -106$
2 GHz to 3 GHz	$\leq -103$
3 GHz to 4 GHz	$\leq -98$

### Test Description

The DANL test is a measurement of the noise generated internally by the instrument. With the RF 50  $\Omega$  input terminated in a 50  $\Omega$  load, the DANL is measured at several frequencies. A visual check is made to ensure the measurement is not done in the presence of a spurious response.

### Required Equipment

Instrument	Recommended HP/Agilent Model Number	Alternative HP/Agilent Model Number
Termination 50 $\Omega$	909A option 012	

**Figure 2-4**

**DANL/Noise Figure Test Setup**

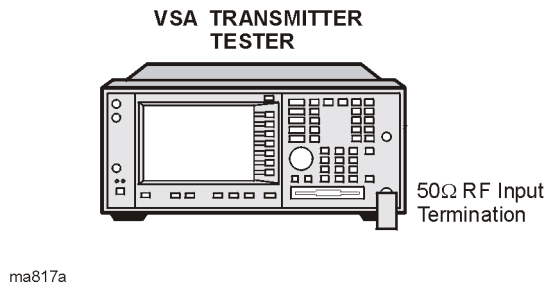



## Procedure

1. If the auto alignment for the UUT has not been run within the last hour, run it by pressing **System, Alignment, and Align All Now**.
2. Preset the UUT by pressing **Preset**.
3. Initialize the parameters for the instrument, as listed in [Table 2-12, “UUT Initialization,”](#) by performing the following steps:
  - a. Press **MODE** and **Basic**.
  - b. To expand the Spectrum window to full screen, ensure that the Spectrum window is highlighted and press **Zoom**.  
  
If the Spectrum window is not highlighted, press **Next Window** until the Spectrum window is highlighted and then press **Zoom**.
  - c. Press **FREQUENCY, Center Freq, 19.995, and MHz**.
  - d. Press **SPAN, Span, 10, and kHz**.
  - e. Press **Meas Setup, Res BW, 1, and kHz**.
  - f. Press **Meas Setup, Average, Avg Number, 100, and Enter**.
  - g. Press **View/Trace, Trace Display, and Average**.
  - h. Press **AMPLITUDE, Ref Scale/Div, 5, and dB**.
  - i. Press **AMPLITUDE, Ref Value, -85, and dBm**.

**Table 2-12**

### UUT Initialization

Parameter		Setting
Mode		Basic
Measure		Spectrum
Frequency	Center	19.995 MHz
	Span	10 kHz
Resolution Bandwidth		1 kHz
ADC Range	Auto/On/Off	Auto
Input Attenuation		0 dB
Average	On/Off	On
	Mode	Exp
	Type	Log-Pwr Avg
	Number	100
Y Scale	Ref Value	-85 dBm
	dB/Div	5 dB

**Table 2-12 UUT Initialization (Continued)**

Parameter	Setting
Trace Display	Average

4. Connect 50 Ω termination to RF input of the UUT.

**NOTE**

Ensure that you perform the measurement on the noise floor and not on a residual response within the displayed 10 kHz span. If a residual response appears, disregard the residual response when making the measurement.

5. Measure the average amplitude of the displayed noise level by performing the following steps:
  - a. Determine the average amplitude of the displayed noise floor by visual inspection.
  - b. Set the marker to a point on the trace that is representative of the average value of the display noise floor by pressing **Marker**, **Trace**, and **Spectrum Avg**. Then adjust the RPG knob until the marker is set on the average value point.
  - c. Read the marker value and then enter the average amplitude value into the Measured DANL column of [Table 2-13](#), “[DANL Data Sheet](#).”
6. Perform the following steps for each frequency setting listed in [Table 2-13](#):
  - a. Press **Frequency**, **Center**, “n”, and **MHz**. Where “n” is the next frequency value in the Center Frequency column.
  - b. Wait for the instrument to finish averaging.
  - c. Ensure that the marker is not on a residual responses peak, read the marker value (if necessary, adjust to a point representative of the average noise value), and enter this value into [Table 2-13](#).
7. Compare the measured DANL levels against the test limits listed in [Table 2-13](#).

**Table 2-13 DANL Data Sheet**

Center Frequency (MHz)	Measured DANL (dBm)	Test Limits (dBm)
19.995		≤ -90
1999.995		≤ -106
2999.995		≤ -103
3999.995		≤ -98

## Phase Noise

### Test Limits

Center Frequency (MHz)	Frequency Offset (kHz)	Limit (dBc/Hz)
600	10	$\leq -85$
600	30	$\leq -90$
900	10	$\leq -80$
900	30	$\leq -90$
1900	10	$\leq -70$
1900	30	$\leq -90$

### Test Description

The phase noise test verifies that phase noise is within acceptable limits. In this test, the source is connected to the RF Input. With the input attenuator set to 10 dB, the source output amplitude is adjusted to a 7 dBm. Input attenuation and source level remain unchanged throughout the test. The noise marker function is used to measure the phase noise at various offsets from the center frequency.

#### NOTE

When phase noise is measured, the phase noise of the source and the UUT are combined. Phase noise components only add, and therefore the phase noise of the source is an important consideration. The limits and measurement points for this test have been established for a source with an absolute SSB Phase Noise of  $\leq 110$  dBc at 10 kHz offset and  $\leq 120$  dBc at 30 kHz offset. If you are using a source other than those recommended in “[Required Test Equipment](#)” on page 41, ensure that it meets the critical specifications listed. However, if your source does not meet these specifications, you can complete the test by increasing the test limits. Alternatively, the spectral purity of most sources can be improved by connecting the source frequency reference to a house reference (usually 10 MHz).

## Required Equipment

(include cables and connectors)

Instrument	Recommended HP/Agilent Model Number	Alternative HP/Agilent Model Number
Synthesized Signal Generator	8663A	8662A, 8664A, 8665A, 8643A, or 8644A w/ Option 002
Cable: Type N, (2 required)	11500C	

**Figure 2-5** Phase Noise Test Setup

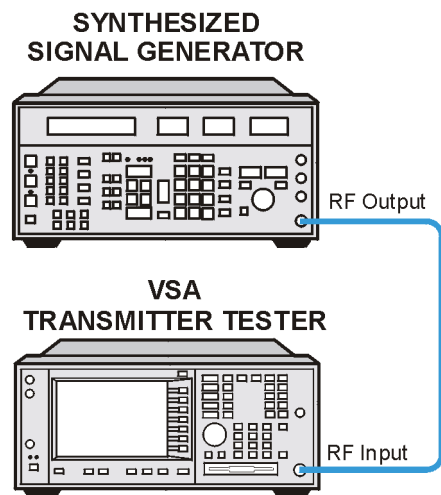

ma82a

## Procedure

1. If the auto alignment for the UUT has not been run within the last hour, run it by pressing **System**, **Alignment**, and **Align All Now**.
2. Preset the UUT by pressing **Preset**.
3. Initialize the parameters for the instrument, as listed in [Table 2-14, "UUT Initialization,"](#) by performing the following steps:
  - a. Press **MODE**, and **Basic**.
  - b. To expand the Spectrum window to full screen, ensure that the Spectrum window is highlighted and press **Zoom**.

If the Spectrum window is not highlighted, press **Next Window** until the Spectrum window is highlighted and then press **Zoom**.

- c. Press **Marker, Trace, Spectrum Avg**.
- d. Press **FREQUENCY, Center Freq, 600, and MHz**.
- e. Press **SPAN, Span, 800, and Hz**.
- f. Press **Input, Input Atten, 10, and dB**.
- g. Press **Meas Setup, More** until (2 of 2) is displayed, **Advanced, More** until (2 of 2) is displayed, and **ADC Dither** until On is underlined.
- h. Press **Meas Setup, More** until (2 of 2) is displayed, **Advanced, ADC Range, Manual, and -6 dB**.
- i. Press **Meas Setup, More** until (2 of 2) is displayed, **Advanced, and Pre-ADC BPF**, until Off is underlined.
- j. Press **Meas Setup, Average, Avg Number, 5, and Enter**.
- k. Press **Meas Setup, Average, Avg Type, and Pwr Avg (RMS)**.
- l. Press **View/Trace, Trace Display, and Average**.

**Table 2-14 UUT Initialization**

Parameter		Setting
Mode		Service
Measure		Spectrum
Frequency	Center	600 MHz
	Span	800 Hz
Resolution Bandwidth		Auto
Attenuation		10 dB
Average	On/Off	On
	Mode	Exp
	Type	RMS
	Number	5
ADC Range	Manual	-6
ADC Dither	On/Off	On
Pre ADC BPF	On/Off	Off
Trace Display		Average
Marker 1		Spectrum Avg

4. Preset the signal source and initialize the parameters as shown in Table 2-15, “Synthesizer Signal Generator Initialization.”

**Table 2-15**

**Synthesizer Signal Generator Initialization**

<b>Parameter</b>	<b>Setting</b>
Frequency	600 MHz
Function	Sine Wave
Amplitude	7 dBm

5. Configure the test equipment as shown in Figure 2-5, “Phase Noise Test Setup.”
6. Perform the following steps to establish the source reference amplitude:
  - a. Set the signal source frequency to 600 MHz.
  - b. If the trace is not on the display, adjust the amplitude reference value by pressing **Amplitude** and **Ref Value**. Then use the RGB knob to adjust the reference value to bring the trace onto the display.
  - c. Press **Search**.
  - d. Adjust the source amplitude until the UUT measures  $7 \text{ dBm} \pm 0.5$ .
  - e. Press **Restart**.
  - f. Wait for the transmitter tester to finish averaging.
  - g. Read the marker value in dBm.
  - h. Record the measured value as  $Y_{i \text{ ref}}$ .

$$Y_{i \text{ ref}} = \text{_____ dBm}$$

7. Reset the UUT parameters to measure the phase noise by performing the following steps:
  - a. Press **Meas Setup, Res BW, 5, Hz**.
  - b. Press **Meas Setup, More** until (2 of 2) is displayed, **Advanced, ADC Range, and Auto**.
  - c. Press **Meas Setup, More** until (2 of 2) is displayed, **Advanced, and Pre-ADC BPF**, until On is underlined.
  - d. Press **Marker, Function, and Noise**.

**Table 2-16**

**UUT Initialization**

Parameter		Setting
Frequency	Center	Center Frequency
Resolution Bandwidth		5 Hz
Pre ADC BPF	On/Off	On
ADC Range	Auto/On/Off	Auto
Marker	Frequency	Noise Marker Frequency

8. If the trace is not on the display, adjust the amplitude reference value by pressing **Amplitude** and **Ref Value**. Then use the RGB knob to adjust the reference value to bring the trace onto the display.
9. Perform the following steps for each frequency setting listed in [Table 2-17, "Measurement Settings"](#):
  - a. Set the signal source frequency to the value listed in the Source Frequency column of [Table 2-17](#).
  - b. Set the center frequency on the UUT by pressing **FREQUENCY, Center Freq, "n", and MHz**. Where "n" is the frequency value in the Center Frequency column.  
  
For example:  
Press **FREQUENCY, Center Freq, 600.010000, and MHz**.
  - c. Set the noise marker frequency by pressing **Marker, "n", and MHz**. Where "n" is the frequency value in the Noise Marker Frequency column.  
  
For example:  
Press **Marker, 600.010000, and MHz**.

**Table 2-17 Measurement Settings**

Source Frequency (MHz)	Center Frequency (MHz)	Noise Marker Frequency (MHz)
600	600.010000	600.010000
600	600.030000	600.030000
900	900.010000	900.010000
900	900.030000	900.030000
1900	1900.010000	1900.010000
1900	1900.030000	1900.030000

- d. Press **Restart**.
- e. Wait for the instrument to finish averaging.
- f. Read the noise marker value in dBm.
- g. Record the measured value in the Measured  $Y_i$  dBm/Hz column in [Table 2-18, "Phase Noise Report."](#)
- h. Calculate the phase noise in dBc/HZ using the following equation and record in the Calculated  $Y_i$  dBc/Hz column of [Table 2-18](#).

$$Y_i \text{ dBc/Hz} = Y_i \text{ dBm/Hz} - Y_{i \text{ ref}}$$

**Table 2-18 Phase Noise Report**

Carrier Frequency (MHz)	Frequency Offset (kHz)	Measured $Y_i$ dBm/Hz (dBm/Hz)	Calculated $Y_i$ dBc/Hz (dBc/Hz)	Test Limit (dBc/Hz)
600	10			$\leq -85$
600	30			$\leq -90$
900	10			$\leq -80$
900	30			$\leq -90$
1900	10			$\leq -70$
1900	30			$\leq -90$



## Residual Responses

### Test Limits

Frequency Range	Limit
20 MHz to 2 GHz	≤ -85
2 GHz to 4 GHz	≤ -80

### Test Description

The residual response test measures the instrument residual responses. With the RF 50 Ω input terminated in a 50 Ω load, internal residual responses are measured at various frequencies between 50 MHz and 4 GHz. There are multiple residual responses across the frequency spectrum of the instrument. The residual responses are measured at only a few representative frequency points.

### Required Equipment

Instrument	Recommended HP/Agilent Model Number	Alternative HP/Agilent Model Number
Termination 50 Ω	909A option 012	

Figure 2-6

### Residual Responses Test Setup

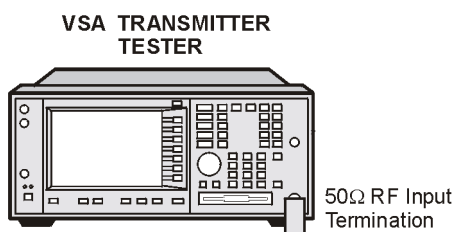

ma817a

### Procedure

1. If the auto alignment for the UUT has not been run within the last hour, run it by pressing **System**, **Alignment**, and **Align All Now**
2. Preset the UUT by pressing **Preset**.

3. Initialize the parameters for the instrument, as listed in [Table 2-19](#), “[UUT Initialization](#),” by performing the following steps:
  - a. Press **MODE** and **Basic**.
  - b. To expand the Spectrum window to full screen, ensure that the Spectrum window is highlighted and press **Zoom**.  
If the Spectrum window is not highlighted, press **Next Window** until the Spectrum window is highlighted and then press **Zoom**.
  - c. Press **Marker**, **Trace**, and **Spectrum Avg**.
  - d. Press **FREQUENCY**, **Center Freq**, **50**, and **MHz**.
  - e. Press **SPAN**, **Span**, **5**, and **MHz**.
  - f. Press **Meas Setup**, **More** until (2 of 2) is displayed, **Advanced**, **More** until (2 of 2) is displayed, and **ADC Dither** until Off is underlined.
  - g. Press **Meas Setup**, **More** until (2 of 2) is displayed, **Advanced**, **ADC Range**, and **Auto**.
  - h. Press **View/Trace**, **Trace Display**, and **Average**.
  - i. Press **Amplitude**, **Ref Value**, **20**, and **dB**.

**Table 2-19**

**UUT Initialization**

Parameter		Setting
Mode		Basic
Measure		Spectrum
Frequency	Center	50 MHz
	Span	5 MHz
Resolution Bandwidth		10 kHz
Attenuation		0 dB
Average	On/Off	On
	Mode	Exp
	Type	Log-Pwr Avg
	Number	25
ADC Rang	Auto/On/Off	Auto
ADC Dither	On/Off	Off
Pre ADC BPF	On/Off	On
Trace Display		Average
Marker 1		Spectrum Avg

4. Configure the test equipment as shown in Figure 2-6, “Residual Responses Test Setup.”
5. Perform the following steps for each frequency setting listed in [Table 2-20, “Measurement Settings”](#):
  - a. Set the center frequency by pressing **FREQUENCY**, **Center Freq**, “n”, and **MHz**. Where “n” is the frequency value in the Center Frequency column.  
For example:  
Press **FREQUENCY**, **Center Freq**, 50, and **MHz**.
  - b. Set the frequency span by pressing **SPAN**, **Span**, “n”, and **MHz**. Where “n” is the frequency value in the Span Frequency column.  
For example:  
Press **SPAN**, **Span**, 5, and **MHz**.
  - c. Set the resolution bandwidth by pressing **Meas Setup**, **Res BW**, “n”, and **kHz**. Where “n” is the frequency value in the Res BW column.  
For example:  
Press **Meas Setup**, **Res BW**, 10, and **kHz**.

**Table 2-20 Measurement Settings**

<b>Center Frequency (MHz)</b>	<b>Span Frequency (MHz)</b>	<b>Res BW (kHz)</b>
50.00	5	10
740.00	2	7
1804.00	2	7
1917.90	2	7
1990.80	2	7
1992.90	2	7
3768.30	2	5
3899.50	2	5
3900.00	2	5

- d. Press **Search**.
- e. Wait for the instrument to finish averaging.
- f. Read the marker value in dBm.

g. Record the measured value as  $X_i$  in the Measured  $X_i$  column of Table 2-21, "Residual Response Report."

**Table 2-21**      **Residual Response Report**

<b>Carrier Frequency (MHz)</b>	<b>Measured <math>X_i</math> (dBm)</b>	<b>Test Limit (dBm)</b>
50.00		$\leq -85$
740.00		$\leq -85$
1804.00		$\leq -85$
1917.90		$\leq -85$
1990.80		$\leq -85$
1992.90		$\leq -85$
3768.30		$\leq -80$
3899.50		$\leq -80$
3900.00		$\leq -80$

## A

Agilent Technologies URL, 2  
amplitude accuracy, 48  
  test description, 48  
annunciators, 6  
attenuator accuracy, 53  
  test description, 53  
average noise level, 56  
  test description, 56

## C

calibration testing, 39  
Corrections Off error  
  annunciator, 6

## D

DANL, 56  
  test description, 56, 59  
display  
  error annunciators, 6  
display average noise level  
  test description, 56  
displayed average noise level, 56

## E

equipment  
  functional testing, 40  
equipment setup, functional  
  testing, 40  
Error annunciator, 6  
error annunciators, 6  
error messages  
  front panel error queue, 35  
  front panel error/status bar, 6  
error queue, 35, 36  
errors  
  0, 33  
  1 to 99, 23  
  100 to 199, 27  
  -199 to -100, 18  
  200 to 299, 29, 31, 32  
  300 to 399, 30  
  -399 to -300, 10  
  400 to 499, 31  
  -499 to -400, 9, 12  
  descriptions, 7  
  instrument specific, 9, 23  
  not in list, 7  
  querying the error queue, 36  
  SCPI remote interface error  
  queue, 36  
  with no number, 7  
Even Second error annunciator, 6  
External Reference error  
  annunciator, 6

## F

flatness, 43  
  frequency response, 43  
  test description, 43  
frequency response, 43  
  flatness, 43  
  test description, 43  
functional test descriptions, 42  
functional testing, 39  
  before starting, 40  
  getting started, 40  
  test descriptions, 42  
  test equipment, 40  
  test list, 42  
  test setups, 40  
  warmup times, 40

## I

input attenuator accuracy, 53  
  test description, 53  
instrument testing, 39  
instrument-specific errors  
  positive numbers, 9, 23

## M

measurement uncertainties, 39

## N

noise level, 56  
  test description, 56  
noise, display average  
  test description, 56  
noise, displayed average, 56  
noise, phase, 59  
  test description, 59

## P

performance testing, 39  
phase noise, 59

## R

residual, 65  
  test description, 65  
residual responses, 65  
  test description, 65  
responses, residual, 65  
  test description, 65

## S

setups  
  functional testing, 40  
Show Errors key, 35

## T

test descriptions, 42  
  amplitude accuracy, 48  
  attenuator accuracy, 53  
  average noise level, 56  
  DANL, 56  
  displayed average noise level, 56  
  frequency response, 43  
  input attenuator accuracy, 53  
  noise displayed average, 56  
  noise, phase, 59  
  phase noise, 59  
  residual, 65  
  residual responses, 65  
  responses, residual, 65  
test equipment  
  functional testing, 40  
  warm-up times, 40  
test equipment setup, functional  
  testing, 40  
test list  
  functional testing, 42  
  testing, 42  
tests of the instrument, 39

## U

uncertainty analysis, 39  
Unlock error annunciator, 6  
URL (Agilent Technologies), 2

## W

warm-up times  
  functional testing, 40  
  test equipment, 40

